

Product data sheet

Characteristics

HOM115GFI

Mini circuit breaker, Homeline, 15A, 1 pole, 120 VAC, 10 kA AIR, ground fault class A, plug in mount

Product availability : Stock - Normally stocked in distribution facility



Main

Product	Miniature circuit-breaker
Range	Homeline
Current Rating	15 A
Certifications	UL Listed
Voltage Rating	120 V AC
Mounting Type	Plug-in
Number of Poles	1P
Short Circuit Current Rating	10 kA
Number of Spaces	1
Circuit Breaker Type	Ground fault protecting class A 6 mA
Ratings	HACR rated
Electrical Connection	Screw clamp terminals
Wire Size	AWG 14...AWG 10 aluminium/copper)1

Complementary

Tightening torque	36.29 lbf.in (4.1 N.m) 0.00...0.01 in ² (2.5...6 mm ²) AWG 14...AWG 10)
Height	3.13 in (79.50 mm)
Width	1 in (25.40 mm)
Depth	2.98 in (75.69 mm)

Environment

Ambient air temperature for operation	104 °F (40 °C)
---------------------------------------	----------------

* Price is "List Price" and may be subject to a trade discount – check with your local distributor or retailer for actual price.

Ordering and shipping details

Category	00063 - HOM 1 POLE GFI CB,20A MAX
Discount Schedule	DE3D
GTIN	00785901065364
Nbr. of units in pkg.	1
Package weight(Lbs)	0.65 lb(US) (0.29 kg)
Returnability	Yes
Country of origin	MX

Packing Units

Unit Type of Package 1	PCE
Package 1 Height	1.40 in (3.556 cm)
Package 1 width	3.80 in (9.652 cm)
Package 1 Length	5.50 in (13.97 cm)
Unit Type of Package 2	CAR
Number of Units in Package 2	38
Package 2 Weight	23.95 lb(US) (10.864 kg)
Package 2 Height	3.90 in (9.906 cm)
Package 2 width	13.90 in (35.306 cm)
Package 2 Length	20.80 in (52.832 cm)
Unit Type of Package 3	PAL
Number of Units in Package 3	1824
Package 3 Weight	1145.00 lb(US) (519.363 kg)
Package 3 Height	40.00 in (101.6 cm)
Package 3 width	40.00 in (101.6 cm)
Package 3 Length	48.00 in (121.92 cm)

Offer Sustainability

Sustainable offer status	Green Premium product
California proposition 65	WARNING: Cancer and Reproductive Harm - www.P65Warnings.ca.gov
REACH Regulation	REACH Declaration
EU RoHS Directive	Compliant EU RoHS Declaration
Mercury free	Yes
RoHS exemption information	Yes
China RoHS Regulation	China RoHS declaration Product out of China RoHS scope. Substance declaration for your information.
Environmental Disclosure	Product Environmental Profile
Circularity Profile	End of Life Information
Halogen content performance	Halogen free product

Contractual warranty

Warranty	Lifetime
----------	----------

Dimensions

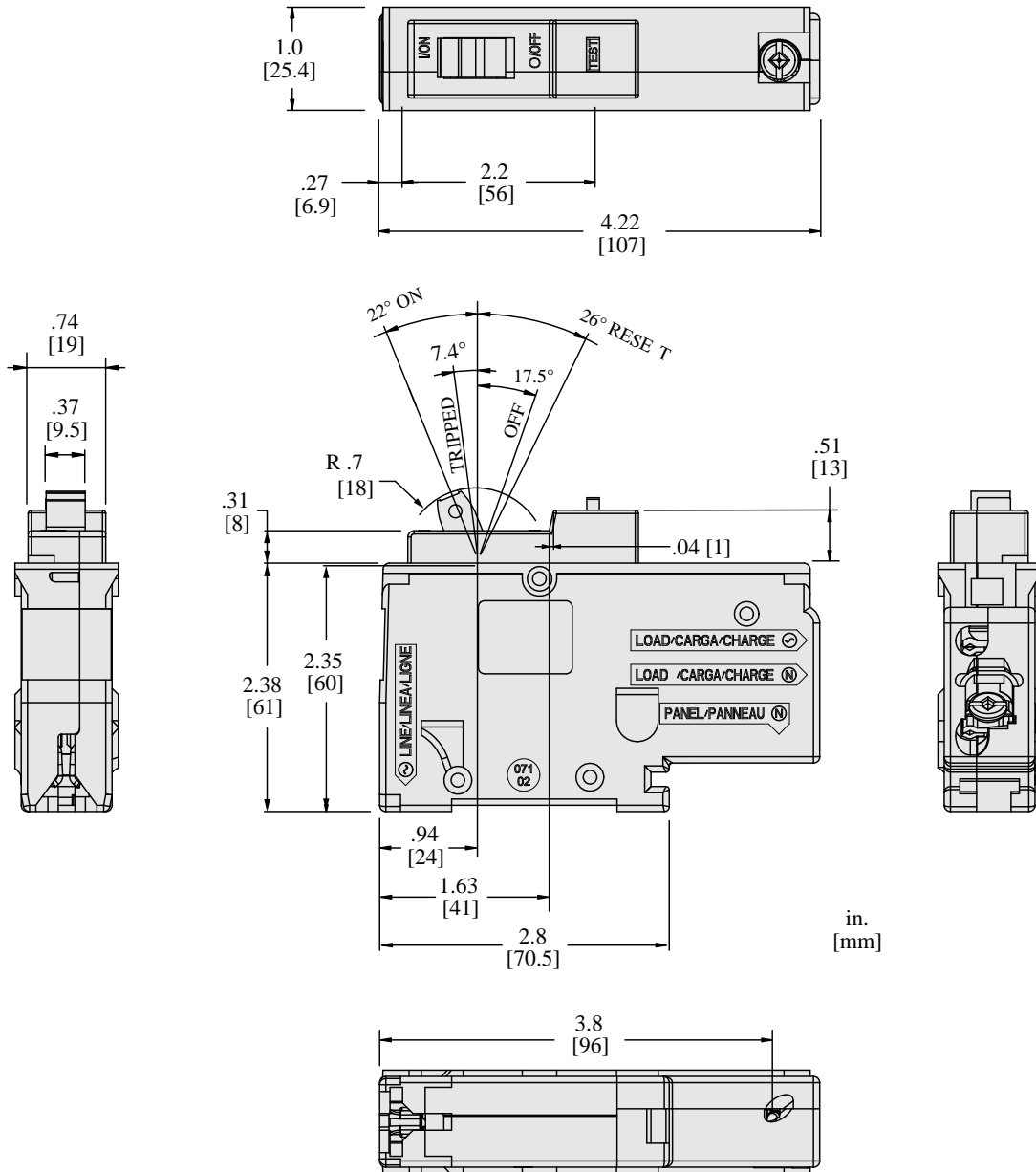

All dimensions are approximate. Also refer to technical drawings and documentation.